

Webster A 390

**SURVEY REFERENCES:**  
-WEBSTER 217  
-WEBSTER A359

WESLEY A. BRINKER & ASHLEY J. SEIFERT  
OR VOL 3527 - PG 217(PARCEL 3)  
99.68 ACRES (PER TAX RECORD)  
P.N.: W75-512-060000020000

WYNN A. BRINKER & JAN LYNN BRINKER, TRUSTEES  
OR VOL 3933 - PG 779(PARCEL 3)  
20 ACRES (RECORDED)  
P.N.: W75-512-060000027000

WAYNE W. BUCHMAN, ET AL  
OR VOL 3683 - PG 360(PARCEL 10)  
38 ACRES (PER TAX RECORD)  
P.N.: W75-512-070000029000

NW COR.,  
NE 1/4,  
SEC. 7

N. LINE, NE1/4

N 89°44'34" E 2648.00'

NE COR.,  
NE 1/4,  
SEC. 7  
POB 5  
POC 1-4 & E

WESLEY A. BRINKER & ASHLEY J. SEIFERT  
OR VOL 3527 - PG 217(PARCEL 4)  
17 ACRES (PER TAX RECORD)  
P.N.: W75-512-070000019000

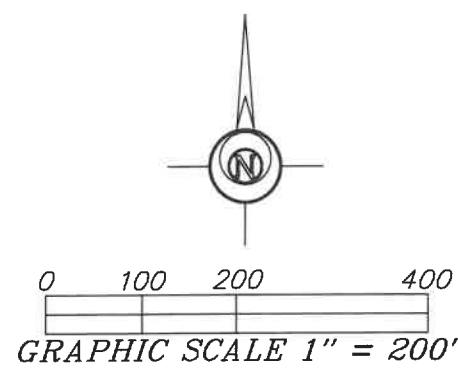

KENNETH A. BRINKER, TRUSTEE  
OR VOL 2370 - PG 708  
79.44 ACRES (RECORDED)  
P.N.: W75-512-070000001000

BRIAN L. & DENISE PICKEREL  
OR VOL 3528 - PG 980  
25.793 ACRES (RECORDED)  
P.N.: W75-512-070000017001

**LEGEND**  
● 5/8 INCH REBAR W/ID CAP SET  
○ 1/2 INCH REBAR FOUND  
CM CONCRETE MONUMENT FOUND  
ST STONE FOUND  
POC POINT OF COMMENCEMENT  
POB POINT OF BEGINNING

**NOTE: SURVEY BEARINGS  
BASED ON OHIO NORTH ZONE  
STATE PLANE COORDINATES  
OBTAINED FROM THE OHIO DOT  
VRS NETWORK**

THIS SURVEY WAS PERFORMED WITHOUT THE  
BENEFIT OF A TITLE EXAMINATION. BEYOND  
THE DEED DOCUMENTS CITED ON THE SURVEY  
DRAWING THERE MAY BE RECORDED OR UN-  
RECORDED EASEMENTS AND/OR  
ENCUMBRANCES BENEFITING OR ENCUMBERING  
THE SURVEYED PROPERTY WHICH ARE NOT  
SHOWN ON THIS DRAWING.



**DRAINAGE EASEMENT**  
0.877 ACRES

**PARCEL 1**  
0.703 AC.  
PART P.N.: W75-512-070000001000

**PARCEL 4**  
5.100 AC.  
0.204 AC. IN BANKS RD. R/W  
PART P.N.: W75-512-070000001000

**PARCEL 3**  
5.100 AC.  
0.204 AC. IN BANKS RD. R/W  
PART P.N.: W75-512-070000001000

**PARCEL 2**  
1.257 AC.  
0.051 AC. IN BANKS RD. R/W  
PART P.N.: W75-512-070000001000  
ALL P.N.: W75-512-070000002000

N 01°22'04" E 1316.27'

SANDERS FAMILY FARMS, LLC  
OR VOL 3885 - PG 413(PARCEL 4)  
52.02 ACRES (RECORDED)  
P.N.: W75-512-070000017000

SW COR.,  
N 1/2,  
NE 1/4

S. LINE, N1/2, NE1/4

S 89°50'21" W 2147.60'

SE COR.,  
NE 1/4,  
SEC. 7

I HEREBY CERTIFY THIS TO BE A SURVEY MADE UNDER MY SUPERVISION  
AND THAT THE MONUMENTS ARE FOUND AND/OR SET AS INDICATED.

3-16-23  
Date

*Seth D. Schroeder*  
Seth D. Schroeder, P.S.  
Registered Surveyor No. 8784  
115 S. Fair Avenue, Suite A  
Ottawa, Ohio 45875  
419-523-5789

WAYNE W. BUCHMAN, ET AL  
DEED VOL 756 - PG 322(PARCEL 2)  
45 ACRES (RECORDED)  
P.N.: W75-512-070000003000

KENNETH A. BRINKER, TRUSTEE  
OR VOL 2370 - PG 710  
0.56 ACRES (RECORDED)  
P.N.: W75-512-070000002000

WAYNE W. BUCHMAN, ET AL  
DEED VOL 778 - PG 46  
51.667 ACRES (RECORDED)  
P.N.: W75-512-070000006500

**SURVEY PLAT FOR:**  
KENNETH BRINKER  
THE NORTH HALF OF THE  
NORTHEAST QUARTER OF  
SECTION 7, T5N - R12E,  
WEBSTER TOWNSHIP  
WOOD COUNTY, OHIO

**Bockrath & Associates**  
Engineering and Surveying, LLC  
115 S. Fair Avenue, Suite A - Ottawa - Ohio  
Phone: 419.523.5789

~C/L BANKS ROAD (40' R/W)~  
(C/L of R/W & SECTION LINE FALL IN AN OPEN DITCH)

Webster A 390