

Milton
A
312

SURVEY FOR: SANDRA K. ENGLE & PAMELA J. KETZENBARGER

SW 1/4, SECTION 03
T-4-N, R-9-E
MILTON TOWNSHIP, WOOD CO., OHIO

W. 1/4 COR.
SEC. 03
5/8" IRON ROD FD.
(CO. REF.)

TPOB-A
POC-B

MILTON ROAD
N-00°-44'-21"-E

WEST LINE
SW 1/4, SEC. 03
1328.66'

SW. COR.
SEC. 03
5/8" IRON ROD FD.
(CO. REF.)

LEONA B. COX LW ETAL
VOL. 610, PAGE 551
K40-409-0300-00-018-000

PAULA C. DEWEESE TRUSTEE
VOL. 2214, PAGE 124
K40-409-0300-00-017-000

SANDRA K. ENGLE &
PAMELA J. KETZENBARGER
VOL. 2705, PAGE 624
K40-409-0300-00-019-000

SHARON A. ROBINSON LE ETAL
VOL. 2946, PAGE 227
K40-409-0300-00-020-000

DEANNA COX TRUSTEE
VOL. 2355, PAGE 232
K40-409-0300-00-022-000

N. 1/4 COR.
SEC. 03
P.K. NAIL FD.
(CO. REF.)

SAND RIDGE ROAD
NORTH LINE, NW 1/4, SEC. 03

SET AT INTERSECTION
OF SECTION LINES

E. 1/4 COR.
SEC. 03
MAG NAIL
(CO. REF.)

JANET LEE KOLLMEIER
VOL. 3042, PAGE 122
K40-409-0300-00-030-000

JANET LEE KOLLMEIER
VOL. 3042, PAGE 122
K40-409-0300-00-029-000

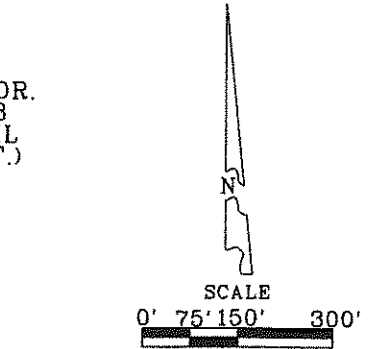

LEGEND
● - 30" CAPPED 5/8" IRON ROD SET
"BARNHISEL S-7678"
● - MAG NAIL SET

I HEREBY CERTIFY THIS
SURVEY TO BE CORRECT
AND TRUE TO THE BEST
OF MY KNOWLEDGE.

Michael D. BarnhiseL
MICHAEL D. BARNHISEL
REG. SURVEYOR #S-7678
DATE: 11-19-16

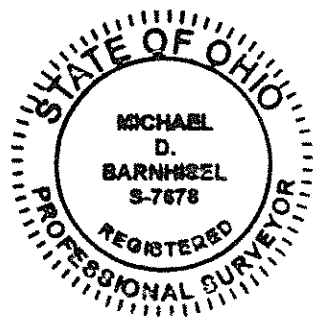

THE BEARINGS REFERRED TO HEREIN ARE
BASED UPON AN ASSUMED MERIDIAN
AND ARE USED ONLY FOR THE PURPOSE
OF ANGULAR MEASUREMENT.

(50' RECORD RIGHT OF WAY AS PER
WOOD COUNTY ENGINEER'S OFFICE.)

SURVEY REFS.
E. J. METZGER APRIL 1934.
HERBERT BEHRMAN NOVEMBER 1996.

S. 1/4 COR.
SEC. 20
MAG NAIL SET.
(FROM CO. FIELD
NOTES AND REF.)

Milton
A
312